

Type A

Unit #1

2 bedroom + office (flex space)

2 bathroom

1 car garage

1,620 GSF*

302 GSF Garage

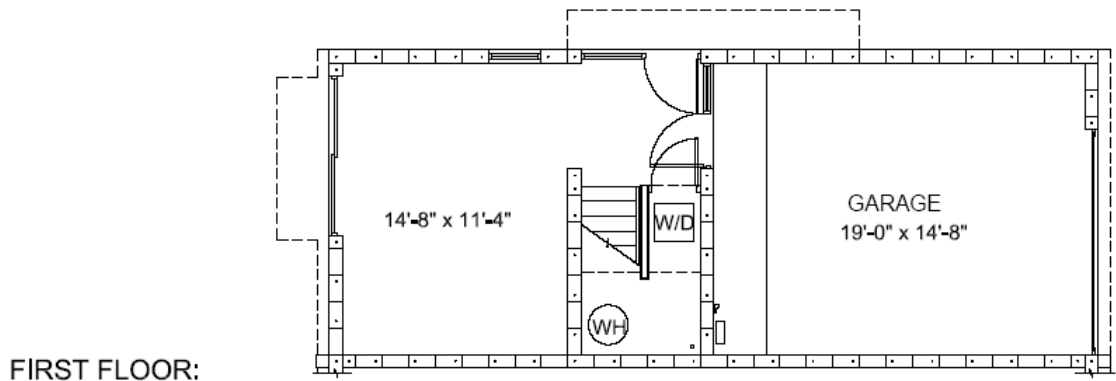
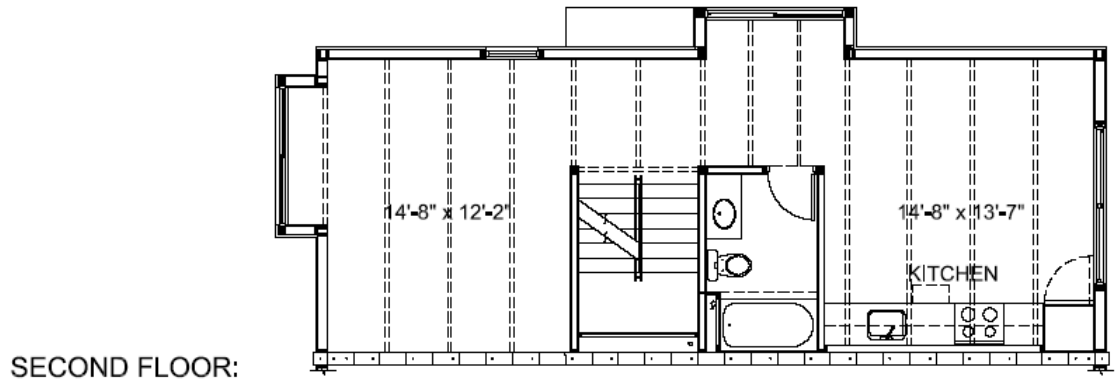
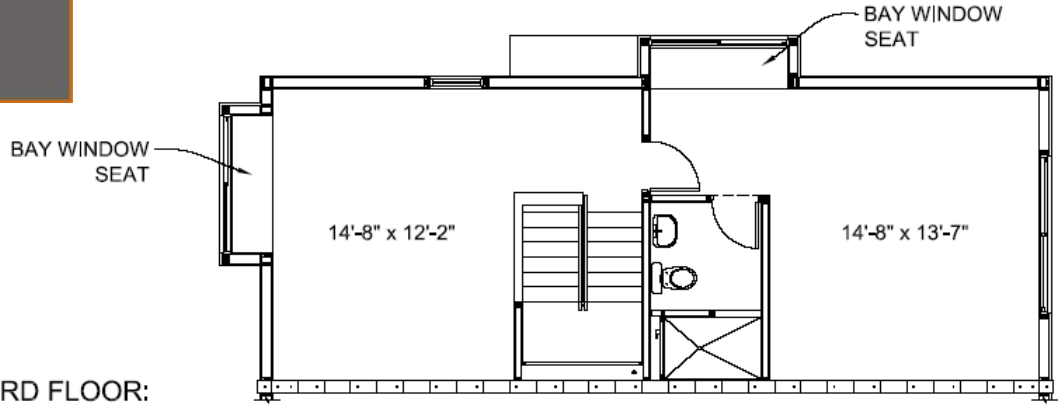

Sales by:
Durnford Group, LLC
Stacie Durnford, Designated Broker
602.791.4404

www.roosevelt11.com



*1,456 Net Square Feet. Stated dimensions and square footage are approximate. Both gross square footage (measured to the outside of the exterior walls and to the middle of party walls and including all stairwells) and net square footage (measured to the inside of walls and including all stairwells) are provided—livable square footage may be less. Seller reserves the right to change or withdraw any offer at any time. Prices subject to change without notice. Floorplans and renderings are artist's conception and may contain options which are not standard in all units. Seller reserves the right to make changes to floorplans, specifications, dimensions and elevations without prior notice.