

Type C

Unit #3

2 bedroom + office (flex space)

2 bathroom

1 car garage

1,522 GSF*

290 GSF Garage

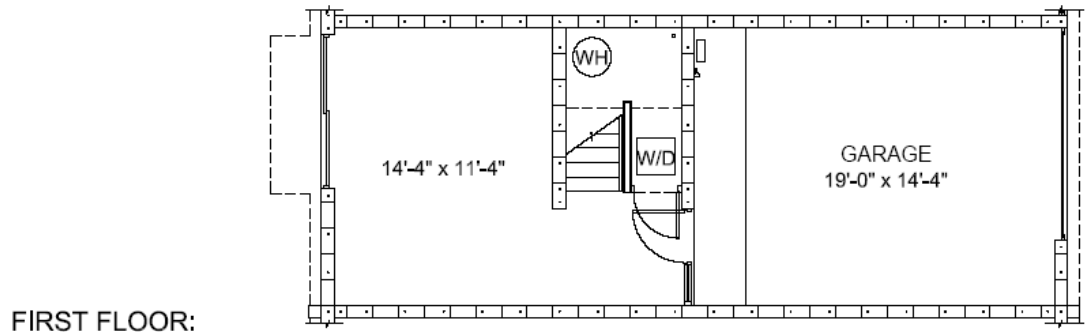
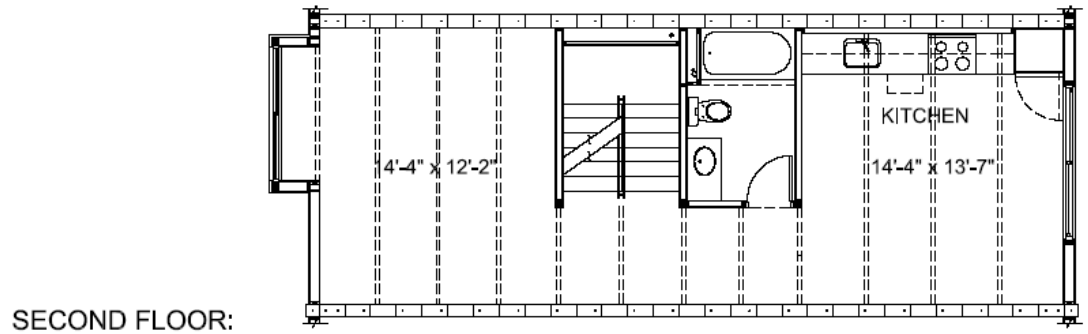
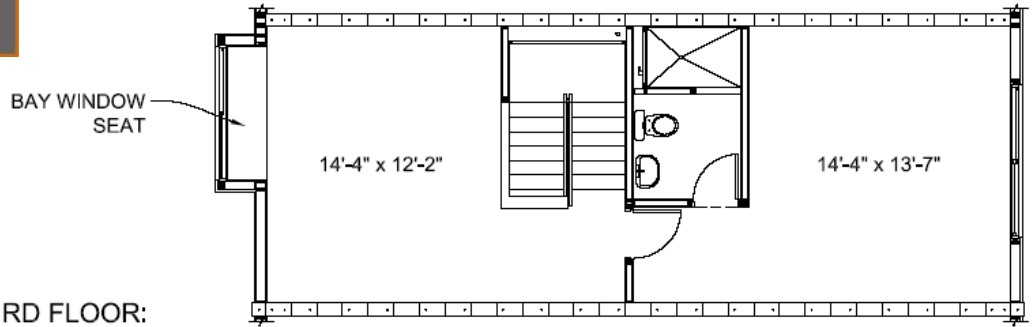

Sales by:
Durnford Group, LLC
Stacie Durnford, Designated Broker
602.791.4404
info@durnfordgroup.com

www.roosevelt11.com

